

# DOUBLE SYSTEM

## MP DUAL PH – REG REDOX

Data  
Sheet

### DESCRIPTION

- ✓ Double system with built in PH /Redox and Temperature controller
- ✓ Flow rate display in percentage
- ✓ 3 different functioning mode: **constant, ON / OFF, proportional**
- ✓ menu available in 4 languages: **ITALIAN, ENGLISH, FRENCH, SPANISH**
- ✓ Password protected
- ✓ Start up delay
- ✓ Time overdose alarm (TAL System)
- ✓ Alarm relay (free contact )
- ✓ Default parameter restore option
- ✓ **PH Stability** mode (settable)
- ✓ **STAND BY** modality
- ✓ Over / under range signal
- ✓ Backlit LCD display
- ✓ PP reinforced case
- ✓ IP 65
- ✓ 230 V 50-60 Hz standard power supply

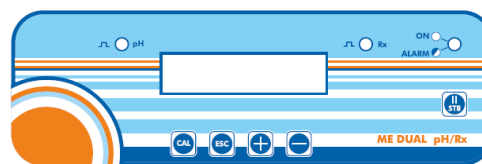

### OPTIONAL

- ✓ Level probe input
- ✓ Flow sensor input
- ✓ ON / OFF switch

### SPECIFICATIONS

#### Standard Version

Case	PP reinforced	-----
Rollers	DELIRIN	-----
Tube	Santoprene	-----
Power consumption	8 Watt	-----
Nuts	PP M10	-----
Fittings	PP 4 x 6	-----
Probe connection	BNC	-----
Foot filter valve	Lip Valve	-----
Suction tube	PVC 4 x 6	-----
Delivery tube	PE 4 x 6	-----

Specifications subject to change without further notice

Via Maestri del Lavoro,5 - 02100 Vazia (RI) – ITALY Tel.:+ 39(0)746-229064; Fax:+ 39(0)746-221224  
e-mail: info@microdos.it ; Web site: www.microdos.it

# DOUBLE SYSTEM

## MP DUAL PH – REG REDOX

Data  
Sheet

SPECIFICATIONS										
Standard	Max l/h	Pressure		Max cc / min	Santoprene Tube	Case	Watt	RPM	Weight	
		Bar	PSI						kg.	Lbs
PH pump	1,5	01	14,7	25	5,8 x 9,3	PP	8	10	3,6	6,7
Plug										230 Vac 50-60 Hz 1A

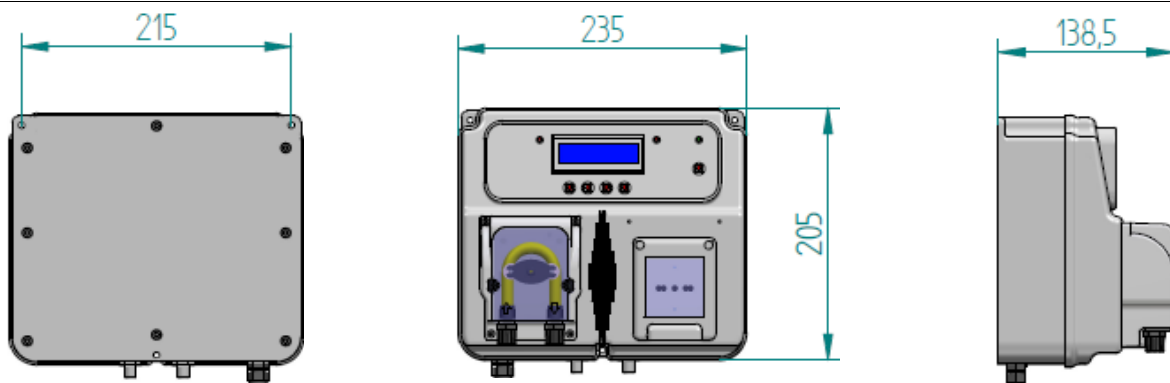

Dimensions

ACCESSORIES KIT				
	Injection valve PP VL VITON	Foot filter PP VL VT	Delivery tube 2mt PE 4x6	Suction tube 2mt PVC 4x6
STANDARD KIT				

Specifications subject to change without further notice

Via Maestri del Lavoro,5 - 02100 Vazia (RI) – ITALY Tel.:+ 39(0)746-229064; Fax:+ 39(0)746-221224  
e-mail: info@microdos.it ; Web site: www.microdos.it